



2010 *International* Application Guide • Volume 9 • Issue 1 • 1-11-10



COMPANIONVAN® SE

## CompanionVan® SE Features

Built on the 2008-2010 Chrysler/Dodge chassis, the CompanionVan® SE (Side Entry) offers the accessibility of traditional lowered-floor minivans in a streamlined, economical package. With a manual door and manual bi-fold ramp, the vehicle is the perfect choice for those who will travel with an attendant. Both front seats and the rear bench seat are retained during the conversion process, allowing seating for up to four ambulatory adults with one wheelchair securement position in the center lowered floor area.

If you are looking for a budget-friendly solution to your personal mobility, this innovative conversion could be the answer.

The CompanionVan® SE is backed by our 3 year/36,000 mile limited and 5 year/100,000 mile rust-through metal protection on every vehicle that leaves the factory. Add to this the original Chrysler warranty for unconverted parts and a nationwide dealer network, and you can rest assured BraunAbility will be there to support you no matter where your travels take you.



### Lowered Floor

The CompanionVan® SE floor is lowered from the B pillars to the rear seat, providing 55" (137 cm) for the center wheelchair securement position. Tie-down tracks and a belt system are included.



# CompanionVan® SE

## CompanionVan® SE (Side Entry) 2008-2010 Chrysler/Dodge Chassis ▶ (Manual Conversion)

See Chassis Information page for Chassis Requirements



### ◀ Lowered Floor

The CompanionVan® SE floor is lowered from the B pillars to the rear seat, providing 137 cm for the center wheelchair securement position. Tie-down tracks and a belt system are included.



### ◀ Manual / Automatic Door

The conversion works with either the Chrysler manual sliding door, or the OEM power sliding door.

### ◀ Manual Foldout Ramp

The lightweight manual foldout ramp offers unparalleled ease of access for wheelchair and scooter users.

### Custom Ground Effects

Adds stylish lines and enhanced appearance.



### ◀ Wheelchair/Occupant Securement System

One belt system is included for use with the floor-mounted tracks.

# CompanionVan® SE Dimensions

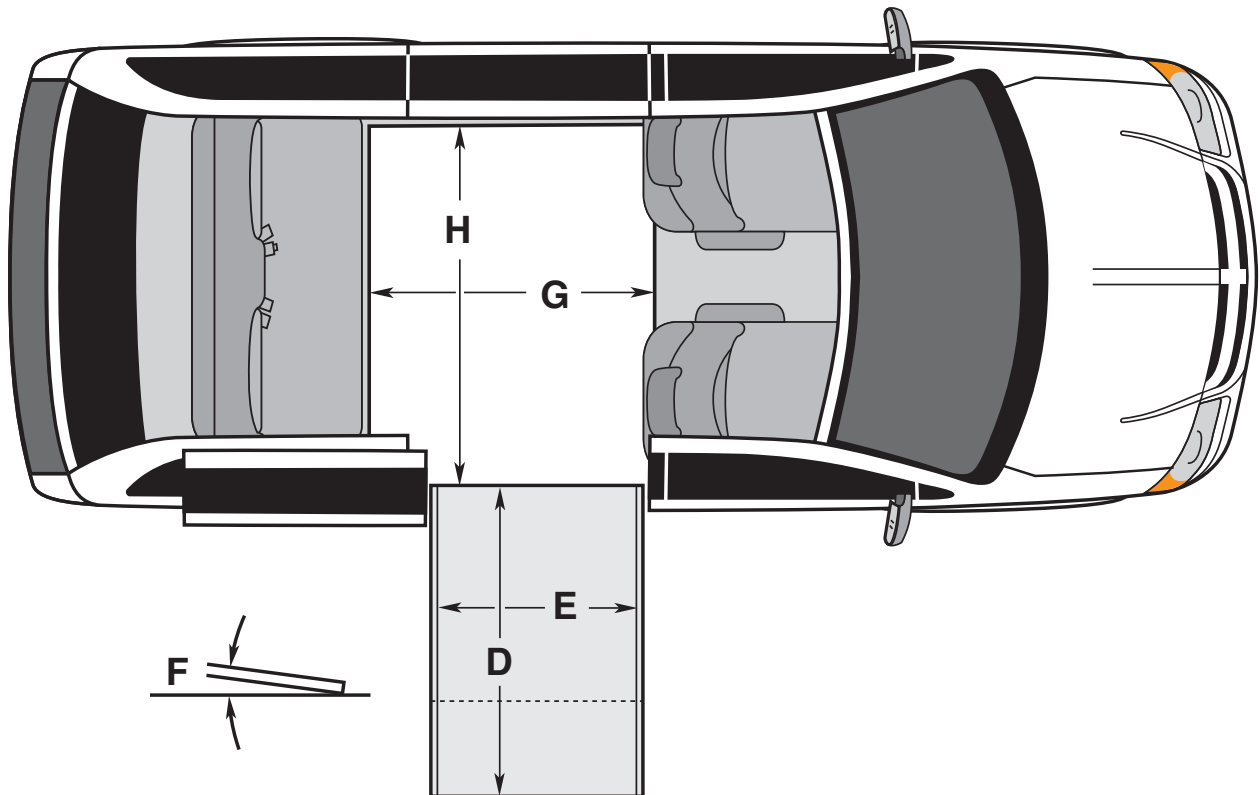
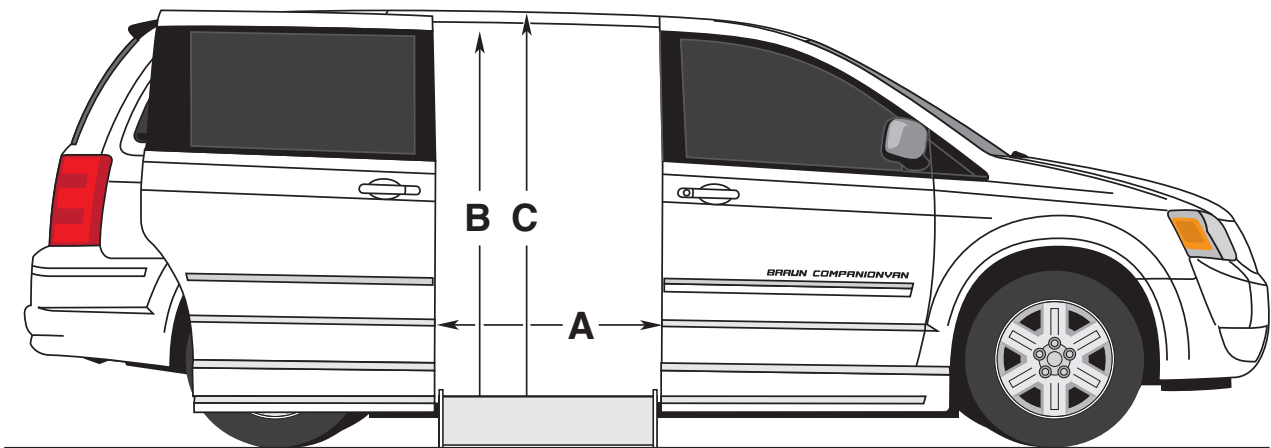

All dimensions are for reference only.

Door Opening Usable Width (Slide Door)	<b>A</b>	<b>31" (79 cm)</b>
Door Opening Usable Height (Slide Door)	<b>B</b>	<b>52-1/2" (133 cm)</b>
Interior Height at Center of Van	<b>C</b>	<b>57-1/4" (145 cm)</b>
Ramp Length	<b>D</b>	<b>52" (132 cm)</b>
Ramp Width (Usable Clear Opening)	<b>E</b>	<b>30" (76 cm)</b>
Ramp Angle	<b>F</b>	<b>11°</b>
Interior Lowered Floor Length	<b>G</b>	<b>55" (140 cm)</b>
Interior Lowered Floor Width at Middle of Ramp	<b>H</b>	<b>59-1/2" (151 cm)</b>

Due to manufacturing tolerances both with the OEM vehicle and the conversion components, all dimensions may vary slightly from those shown.



◀ **E24362CV**

### **Non-Skid Flooring - Altro**

GY (Gray), DK (Dark Khaki) or BK (Black)

Substitute non-skid flooring in lieu of carpet  
(NOT AVAILABLE FOR SHIP-OUT - FACTORY INSTALLED)  
(MUST BE ORDERED PRIOR TO PRODUCTION)



◀ **26558**

### **Retractable Securement Belts** with Tensioning Knobs (4)

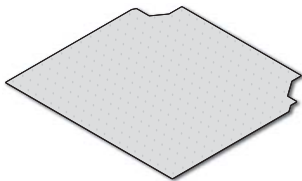

◀ **E51243CV**

### **Protective Carpet Mat**

Clear plastic mat protects carpet from traffic wear.



◀ **33774**

### **Multi Piece Chest and Waist Belt**

Interfaces with standard and optional wheelchair securement systems to facilitate proper occupant restraint with a wide variety of wheelchair configurations.



◀ **E51346K**

### **Rail Delete Kit - Interior Color**

Allows for removal of OEM overhead storage rail for increased headroom down the center of vehicle. New low profile interior panel is color matched to OEM interior. Specify color.  
*(DEALER INSTALLED ONLY)*

**E51127K**

### **Seatbelt Kit** - Required on vehicles with Swivel n' Go Seating

(NOT AVAILABLE FOR SHIP-OUT - FACTORY INSTALLED)  
(MUST BE ORDERED PRIOR TO PRODUCTION)

## Chassis Information

Chassis equipped with Swivel n' Go Seating require new seat belts for center row positions (see pricing page). The Swivel n' Go Seating feature is not retained in the conversion.

Converted chassis are not returned with the center seats. If customer requests center seats, a tracking fee will be applied (see pricing page).

Before ordering or drop-shipping a chassis, we strongly recommend contacting BraunAbility for guidance in deriving payload capacities and selecting equipment and seating options before you purchase the chassis.

BraunAbility will only convert 2008-2010 chassis. Chassis must be in sound condition and must never have been involved in an accident. All chassis are inspected and subject to acceptance/rejection upon arrival at the BraunAbility plant.

**BraunAbility Drop Ship Code 16323**

## Exporting Information

The Braun Corporation can export pre-owned Dodge/Chrysler minivans. These pre-owned chassis have between 15,000 and 50,000 km. However, the Braun conversions will be new. All chassis will be of US specifications, non-US spec vans will not be accepted. It is dependent upon the purchaser to verify their country's import and registration requirements. The chassis will be sold as-is with no OEM warranty. The Braun conversion will carry the standard three-year limited warranty when maintained by a Braun recognized dealer. The Braun Corporation makes no guarantee of ability to import said converted vehicles. All vehicles will be sold on an FOB (any US Sea Port).



[www.braunability.com/international](http://www.braunability.com/international)

**ISO 9001:2000**

631 West 11th Street, Winamac, IN 46996, USA Phone: +1 574 946 6153 Fax: +1 574 946 4670