



2010 *International Application Guide* • Volume 9 • Issue 1 • 1-11-10



MILLENNIUM SERIES™

# Millennium Series™ Wheelchair Lifts

## L955SE3143IB

Useable Platform:  
31" x 43"  
(79 cm x 109 cm)

## L955SE3147IB

Useable Platform:  
31" x 47"  
(79 cm x 119 cm)

## L955SE3151IB

Useable Platform:  
31" x 51"  
(79 cm x 130 cm)

## L955SE3455IB

Useable Platform:  
34" x 55"  
(86 cm x 140 cm)

Explanations of abbreviations: L955 SE 31 43 IB

SE = Side Entry Platform

31 = 31" (79 cm) Clear Platform Width

43 = 43" (109 cm) Clear Platform Length

IB = Inboard Barrier

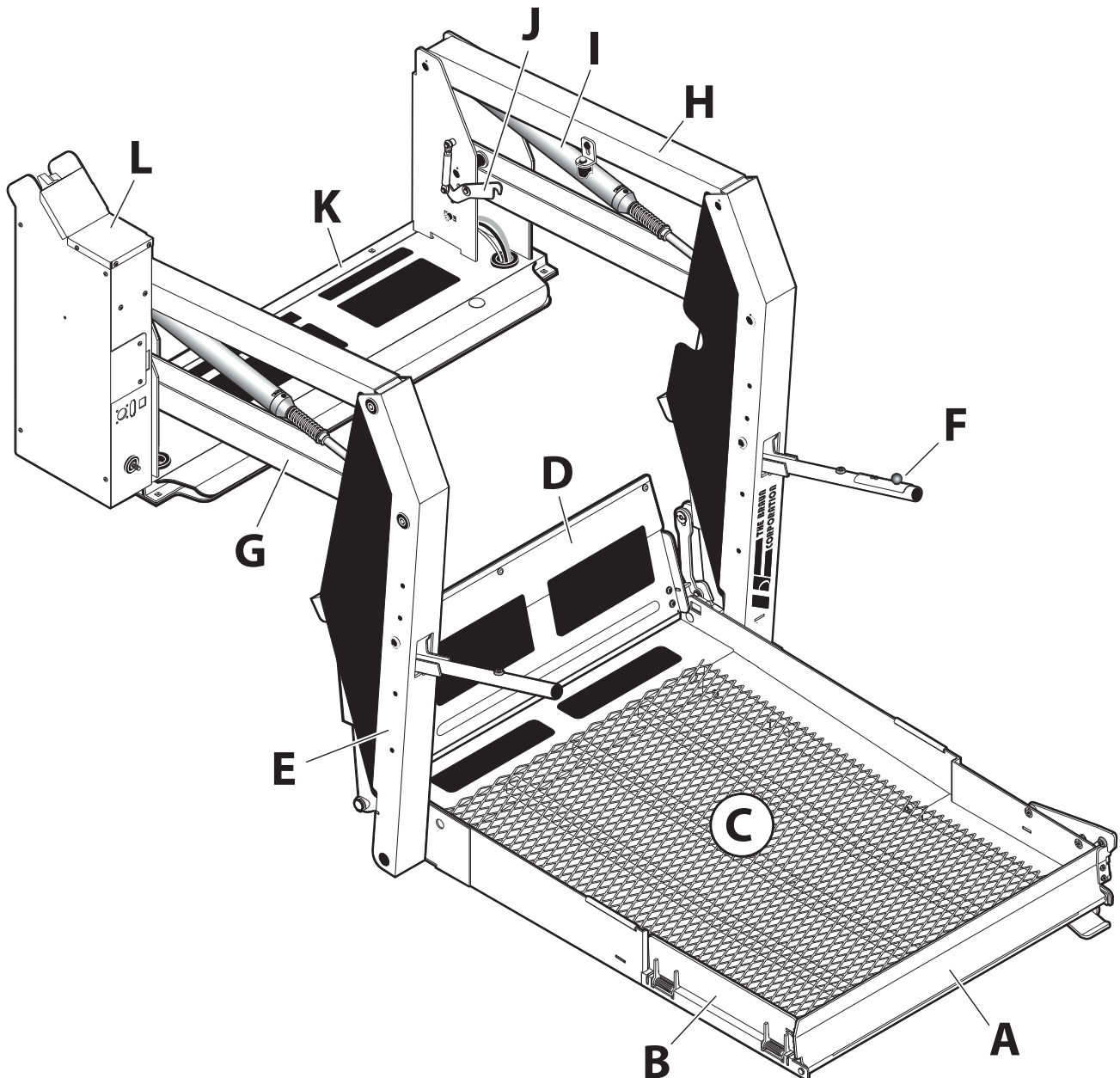

|   |                                     |
|---|-------------------------------------|
| <b>A</b> - Automatic Outboard Barrier         | <b>G</b> - Bottom Parallel Arms (2) |
| <b>B</b> - Side Entry (SE)                    | <b>H</b> - Top Parallel Arms (2)    |
| <b>C</b> - Platform                           | <b>I</b> - Cylinder (2)             |
| <b>D</b> - Inboard Barrier (IB)               | <b>J</b> - Lift-Tite Latch          |
| <b>E</b> - Vertical Arms (2)                  | <b>K</b> - Base Plate               |
| <b>F</b> - Handrails (2), with Up/Down Switch | <b>L</b> - Pump Module              |

# Millennium Series™ Dimensions

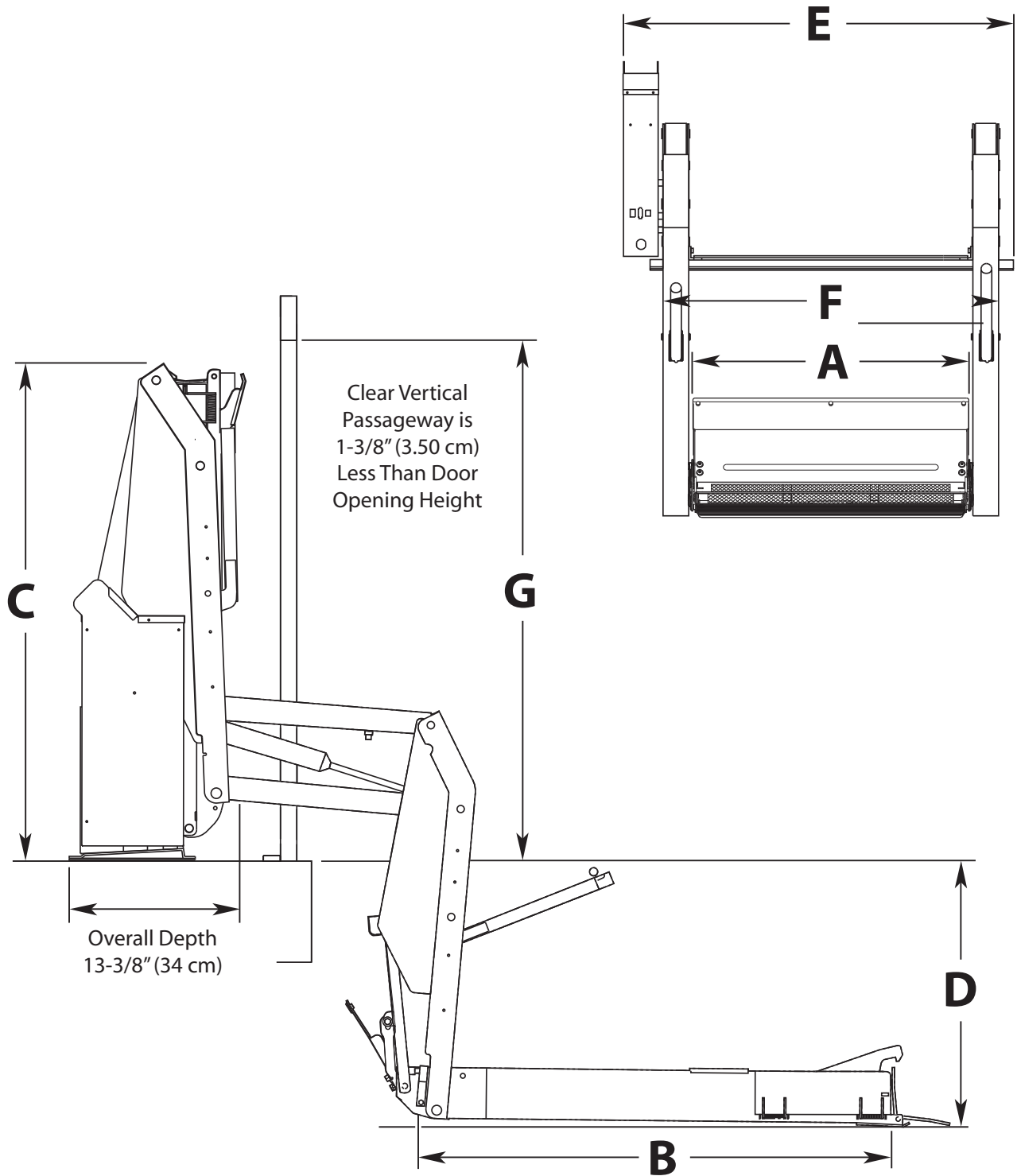

All dimensions are for reference only.

| Millennium Series™ |           |        | A                    | B                     | C                   | D                    | E                  | F                             | G                              |
|--------------------|-----------|--------|----------------------|-----------------------|---------------------|----------------------|--------------------|-------------------------------|--------------------------------|
| Lift Model Number  | Operation |        | Clear Platform Width | Clear Platform Length | Overall Lift Height | Max. Floor to Ground | Overall Lift Width | Min. Clear Door Opening Width | Min. Clear Door Opening Height |
|                    | User      | Attdt. |                      |                       |                     |                      |                    |                               |                                |
| L955SE3143IB       | X         | X      | 31"(79cm)            | 43"(109cm)            | 47.5"(121cm)        | 42"(107cm)           | 46"(117cm)         | 40"(102cm)                    | 47"(119cm)                     |
| L955SE3147IB       | X         | X      | 31"(79cm)            | 47"(119cm)            | 51.5"(131cm)        | 42"(107cm)           | 46"(117cm)         | 40"(102cm)                    | 51"(130cm)                     |
| L955SE3151IB       | X         | X      | 31"(79cm)            | 51"(130cm)            | 55.5"(141cm)        | 42"(107cm)           | 46"(117cm)         | 40"(102cm)                    | 55"(140cm)                     |
| L955SE3455IB       | X         | X      | 34"(86cm)            | 55"(140cm)            | 59.5"(151cm)        | 42"(107cm)           | 49"(124cm)         | 43"(109cm)                    | 59"(150cm)                     |

# Millennium Series™ Specifications

**General Function:** Electrohydraulic, power up/gravity down operation

**Operation:** Hydraulic pump with two lifting cylinders and one outboard barrier cylinder

**Control:** Module mounted switches, handrail Up/Down switch, optional hand-held control and remote

**Hydraulic:** Pressure Max. 2,495 psi (172 bar), Fluid is Univis HVI 26, reservoir is .33 gal (1.25 L)

**Construction:** Steel structure with powder coat finish

**Lift Weight:** 340 lbs (154 kg) - 355 lbs (161 kg) (depending on lift model)

**Lifting Capacity:** 800 lbs (363 kg)

**Operating Temperature:** 19°F to 149°F (-7°C to 65°C)

**Power Supply:** 12V DC or 24V DC

**Current Consumption:** Max. 70A (12V), Max. 35A (24V)



# Millennium Series™ Accessories



◀ **62400-000** Side Swing In-Door Operators



**23170A** Side Slide Door Operator ▶



**15606A**  
Hand-Held  
Control Station Kit

Included at no charge when specified on a lift without door operators. Controls lift functions only.



**34972K**  
Six-Touch Remote  
Control System

(North American Frequency)  
Controls all lift functions as well as door operators (if so equipped)

**34352**  
Extra Transmitter  
for Six-Touch



**26230A**  
Threshold  
Warning Kit

## Millennium Series™ Features

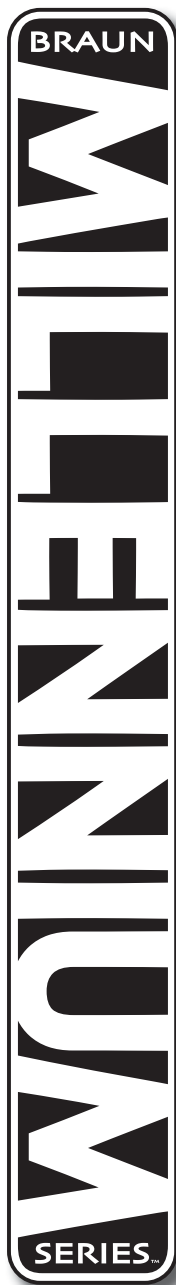

- fully automatic lift, operated by the wheelchair occupant or an attendant
- parallel arm lift with hydraulic cylinders
- color-coded rocker switches integrated on the lift
- additional up/down switch mounted on the handrail
- optional operation by hand-held control box
- optional operation by remote control
- side or rear door application
- miscellaneous platform widths and lengths
- dual handrails for security and convenience
- side entry (SE) platform provides easier access in tight parking situations
- hydraulic automatic outboard barrier that will be in the fully up position before the platform leaves the ground
- mechanical inboard barrier (IB models), ensuring extra safety for the wheelchair occupant
- bridging feature permits the wheelchair user to board the lift from sidewalks or inclines
- integrated back-up pump
- designed for use with automatic door operators
- equipped with an adjustable anti-rattle feature to avoid unpleasant noise in the vehicle during transit
- durable high-gloss powder coated finish
- Lift-Tite system stows the lift platform securely while the vehicle is in transit
- optional threshold warning kit - with the lift away from floor level, an alarm will sound when passengers approach the doorway



[www.braunability.com/international](http://www.braunability.com/international)

ISO 9001:2000

631 West 11th Street, Winamac, IN 46996, USA Phone: +1 574 946 6153 Fax: +1 574 946 4670